



LCD Fuel Gage with Hour Meter Model 2412



LED Fuel Gage with Hour Meter Model 2212



LCD Battery Charge Meter Model 2314



LED Battery Charge Meter Model 2114



LCD Pressure Gage Model 2313



LED Pressure Gage Model 2113



LCD Fuel Gage Model 2312



LED Fuel Gage Model 2112



LCD Temperature Gage Model 2311



LED Temperature Gage Model 2111

DESCRIPTION

Solid state, 52mm round LED and LCD engine gages based on a custom integrated circuit. The series includes temperature, battery charge, pressure and fuel gages and a combination gage which includes a solid state hour meter. Curtis engine controllers prevent engine damage by shutting down systems or activating alarms.

WARRANTY

Three years replacement warranty

Application

Curtis round gages are ideal for use with diesel, gasoline and propane engines of construction, agricultural and material handling vehicles, generator sets, air compressors, forestry equipment and many other rugged applications.

Features

- Easy to read, tri-colored, 10 bar, LEDs display instant "status at a glance", or, gages with optional LCD improves visibility in bright daylight conditions.
- Eye catching, flashing segments (red in LED) indicate operation beyond established parameters, such as under and over voltage.
- Shallow behind-panel depth. Typically, these gages require less than half the depth of conventional electro-mechanical gages.
- Each of the ten display segments is factory programmable to allow for customized monitoring for OEM applications. An expanded resolution "normal voltage" region allows the operator to notice alternator problems before they become serious (for example, 12 to 15V takes up 60% of the 8 to 18V scale).
- Programmable by Curtis to interface with a wide variety of sender inputs – resistive, voltage or current based. These gages accept virtually any input device.
- Two output signals – one at the high end and one at the low end of the display – can be used to activate external alarms or shut down equipment when operating ranges have been exceeded. Ideal for unsupervised equipment.
- Single lit LED/LCD or rising bar graph display modes.
- Available with optional domed lens.
- All gages can be coupled with an optional solid state hour meter in a single 52mm case. The hour meter retains latest accumulated time reading in EPROM memory without the need for external battery backup. With no moving parts, it far outlasts electro-mechanical hour meters.
- Engine controllers 2150, 2250, 2350, 2450 can carry up to 2 amps of load current, allowing for an OEM programmed engine control function without the need for separate senders or relays.

Model Definition

Model number	Function	Display	With hour meter	Output signals	Output signal format	*Program-mable	Case options	Voltage options
2114	Battery charge	LED	No	Two	Logic level	Yes	R or M styles	12 or 24
2154	Battery charge	LED	No	Two	Power MOSFET	Yes	R or M styles	12 or 24
2214	Battery charge	LED	Yes	Two	Logic level	Yes	R or M styles	12 or 24
2254	Battery charge	LED	Yes	Two	Power MOSFET	Yes	R or M styles	12 or 24
2314	Battery charge	LCD	No	Two	Logic level	Yes	R or M styles	12 or 24
2354	Battery charge	LCD	No	Two	Power MOSFET	Yes	R or M styles	12 or 24
2414	Battery charge	LCD	Yes	Two	Logic level	Yes	R or M styles	12 or 24
2454	Battery charge	LCD	Yes	Two	Power MOSFET	Yes	R or M styles	12 or 24
2112	Fuel	LED	No	Two	Logic level	Yes	R or M styles	12 or 24
2152	Fuel	LED	No	Two	Power MOSFET	Yes	R or M styles	12 or 24
2212	Fuel	LED	Yes	Two	Logic level	Yes	R or M styles	12 or 24
2252	Fuel	LED	Yes	Two	Power MOSFET	Yes	R or M styles	12 or 24
2312	Fuel	LCD	No	Two	Logic level	Yes	R or M styles	12 or 24
2352	Fuel	LCD	No	Two	Power MOSFET	Yes	R or M styles	12 or 24
2412	Fuel	LCD	Yes	Two	Logic level	Yes	R or M styles	12 or 24
2452	Fuel	LCD	Yes	Two	Power MOSFET	Yes	R or M styles	12 or 24
2113	Pressure	LED	No	Two	Logic level	Yes	R or M styles	12 or 24
2153	Pressure	LED	No	Two	Power MOSFET	Yes	R or M styles	12 or 24
2213	Pressure	LED	Yes	Two	Logic level	Yes	R or M styles	12 or 24
2253	Pressure	LED	Yes	Two	Power MOSFET	Yes	R or M styles	12 or 24
2313	Pressure	LCD	No	Two	Logic level	Yes	R or M styles	12 or 24
2353	Pressure	LCD	No	Two	Power MOSFET	Yes	R or M styles	12 or 24
2413	Pressure	LCD	Yes	Two	Logic level	Yes	R or M styles	12 or 24
2453	Pressure	LCD	Yes	Two	Power MOSFET	Yes	R or M styles	12 or 24
2111	Temperature	LED	No	Two	Logic level	Yes	R or M styles	12 or 24
2151	Temperature	LED	No	Two	Power MOSFET	Yes	R or M styles	12 or 24
2211	Temperature	LED	Yes	Two	Logic level	Yes	R or M styles	12 or 24
2251	Temperature	LED	Yes	Two	Power MOSFET	Yes	R or M styles	12 or 24
2311	Temperature	LCD	No	Two	Logic level	Yes	R or M styles	12 or 24
2351	Temperature	LCD	No	Two	Power MOSFET	Yes	R or M styles	12 or 24
2411	Temperature	LCD	Yes	Two	Logic level	Yes	R or M styles	12 or 24
2451	Temperature	LCD	Yes	Two	Power MOSFET	Yes	R or M styles	12 or 24

R case has black bezel and flat glass lens M case has black bezel and dome shaped glass lens *Programmable at Curtis factory

Specifications

- Operating voltages 12VDC nominal (9VDC to 16VDC) [Battery Charge Meters 8VDC to 18VDC] 24VDC nominal (18VDC to 32VDC) [Battery Charge Meters 16VDC to 36VDC]
- Connections Six 0.25 inch quick connect terminals.
- Operating temperature -40°C to +85°C
- Storage temperature -50°C to +90°C
- Humidity 95% RH (non-condensing) at +38°C
- Shock SAE J 1378 March 83. Amplitude 44-55 g, half sine, 9-13 ms duration
- Vibration SAE J 1378 March 83 Double amplitude of 1.53mm with frequency sweep for 10-80-10 Hz (20 g max) at 1 minute intervals
- Sealing IP-65 (face), IP-50 (overall)
- Output signal format (logic level) Logic level, 0 to 5V or 5V to 0, programmable Capable of sinking or sourcing 50 µA, maximum
- Output signal format (Power MOSFET) N channel MOSFET (switches ground side only) Programmable; capable of sinking up to 2A, maximum (4A, maximum for single output option)
- Case: Polycarbonate, black
- Lens: Glass
- Bezel: Aluminum, black anodized

Options

- For custom designed gages and option details please contact Curtis.
- Primary Options include:
- Circuit board mountable modules
 - Panels of various configurations
 - Tachometer and Speedometer

Model Encodement Scheme

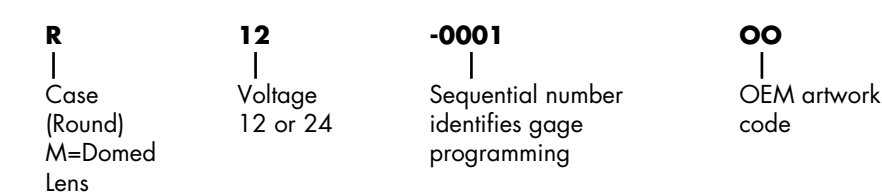

Dimensions: mm (inches)

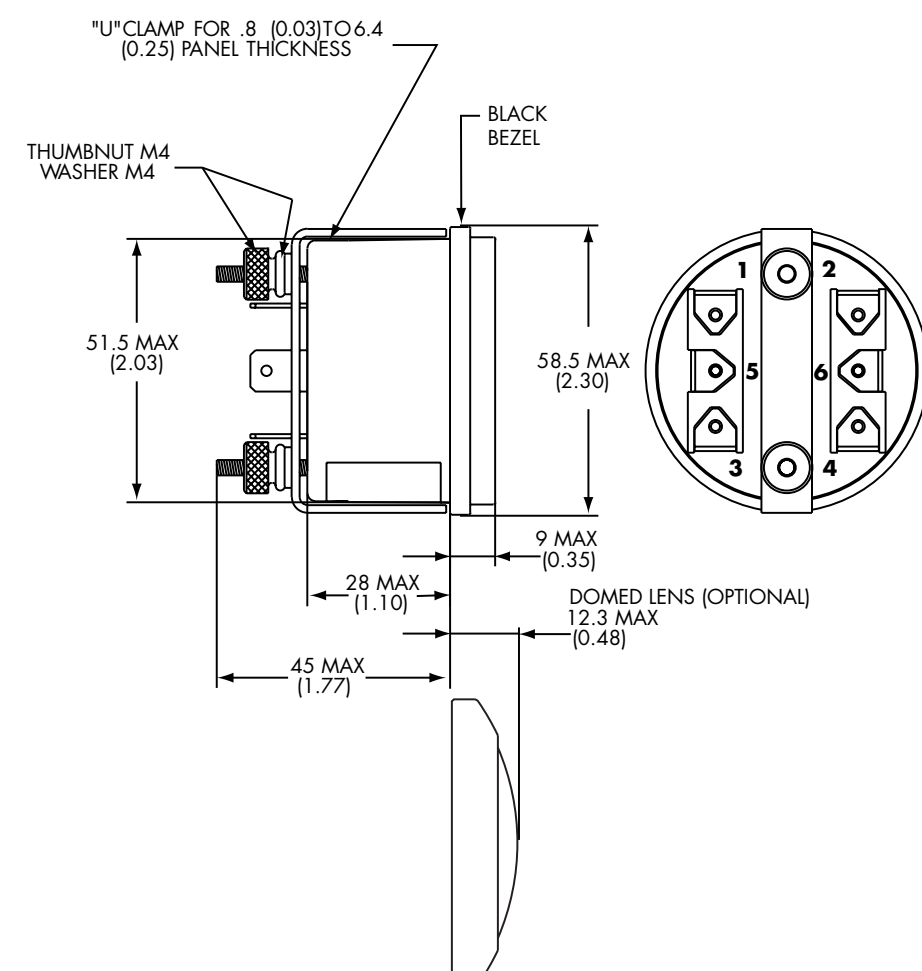

Terminal Assignment Chart

Model number	Function	Terminal 1	Terminal 2 Battery	Terminal 3 Battery	Terminal 4	Terminal 5 Output	Terminal 6 Output	Output format	Output rating
2111	Temperature	Sender input	+	Ground	Sender ground	Higher	Lower	Logic level	50 microAmps, max.; sink or source
2112	Fuel	Sender input	+	Ground	Sender ground	Higher	Lower	Logic level	50 microAmps, max.; sink or source
2113	Pressure	Sender input	+	Ground	Sender ground	Higher	Lower	Logic level	50 microAmps, max.; sink or source
2114	Battery charge	Not connected	+	Ground	Not connected	Higher	Lower	Logic level	50 microAmps, max.; sink or source
2151	Temperature	Sender input	+	Ground	Sender ground	Higher	Lower	Power MOSFET	2 Amps, max.; sink only
2152	Fuel	Sender input	+	Ground	Sender ground	Higher	Lower	Power MOSFET	2 Amps, max.; sink only
2153	Pressure	Sender input	+	Ground	Sender ground	Higher	Lower	Power MOSFET	2 Amps, max.; sink only
2154	Battery charge	Not connected	+	Ground	Not connected	Higher	Lower	Power MOSFET	2 Amps, max.; sink only
2211	Temperature	Sender input	+	Ground	Hour Meter enable	Higher	Lower	Logic level	50 microAmps, max.; sink or source
2212	Fuel	Sender input	+	Ground	Hour Meter enable	Higher	Lower	Logic level	50 microAmps, max.; sink or source
2213	Pressure	Sender input	+	Ground	Hour Meter enable	Higher	Lower	Logic level	50 microAmps, max.; sink or source
2214	Battery charge	Not connected	+	Ground	Hour Meter enable	Higher	Lower	Logic level	50 microAmps, max.; sink or source
2251	Temperature	Sender input	+	Ground	Hour Meter enable	Higher	Lower	Power MOSFET	2 Amps, max.; sink only
2252	Fuel	Sender input	+	Ground	Hour Meter enable	Higher	Lower	Power MOSFET	2 Amps, max.; sink only
2253	Pressure	Sender input	+	Ground	Hour Meter enable	Higher	Lower	Power MOSFET	2 Amps, max.; sink only
2254	Battery charge	Not connected	+	Ground	Hour Meter enable	Higher	Lower	Power MOSFET	2 Amps, max.; sink only
2311	Temperature	Sender input	+	Ground	Sender ground	Higher	Lower	Logic level	50 microAmps, max.; sink or source
2312	Fuel	Sender input	+	Ground	Sender ground	Higher	Lower	Logic level	50 microAmps, max.; sink or source
2313	Pressure	Sender input	+	Ground	Sender ground	Higher	Lower	Logic level	50 microAmps, max.; sink or source
2314	Battery charge	Not connected	+	Ground	Not connected	Higher	Lower	Logic level	50 microAmps, max.; sink or source
2351	Temperature	Sender input	+	Ground	Sender ground	Higher	Lower	Power MOSFET	2 Amps, max.; sink only
2352	Fuel	Sender input	+	Ground	Sender ground	Higher	Lower	Power MOSFET	2 Amps, max.; sink only
2353	Pressure	Sender input	+	Ground	Sender ground	Higher	Lower	Power MOSFET	2 Amps, max.; sink only
2354	Battery charge	Not connected	+	Ground	Not connected	Higher	Lower	Power MOSFET	2 Amps, max.; sink only
2411	Temperature	Sender input	+	Ground	Hour Meter enable	Higher	Lower	Logic level	50 microAmps, max.; sink or source
2412	Fuel	Sender input	+	Ground	Hour Meter enable	Higher	Lower	Logic level	50 microAmps, max.; sink or source
2413	Pressure	Sender input	+	Ground	Hour Meter enable	Higher	Lower	Logic level	50 microAmps, max.; sink or source
2414	Battery charge	Not connected	+	Ground	Hour Meter enable	Higher	Lower	Logic level	50 microAmps, max.; sink or source
2451	Temperature	Sender input	+	Ground	Hour Meter enable	Higher	Lower	Power MOSFET	2 Amps, max.; sink only
2452	Fuel	Sender input	+	Ground	Hour Meter enable	Higher	Lower	Power MOSFET	2 Amps, max.; sink only
2453	Pressure	Sender input	+	Ground	Hour Meter enable	Higher	Lower	Power MOSFET	2 Amps, max.; sink only
2454	Battery charge	Not connected	+	Ground	Hour Meter enable	Higher	Lower	Power MOSFET	2 Amps, max.; sink only